

ILLUSTRATED PARTS BREAKDOWN

ELECTROLUX

14.5 HP 42" LAWN TRACTOR

MODEL NO. P145PH107 (P145PH107B)

PRODUCT NO. 964 77 78-00

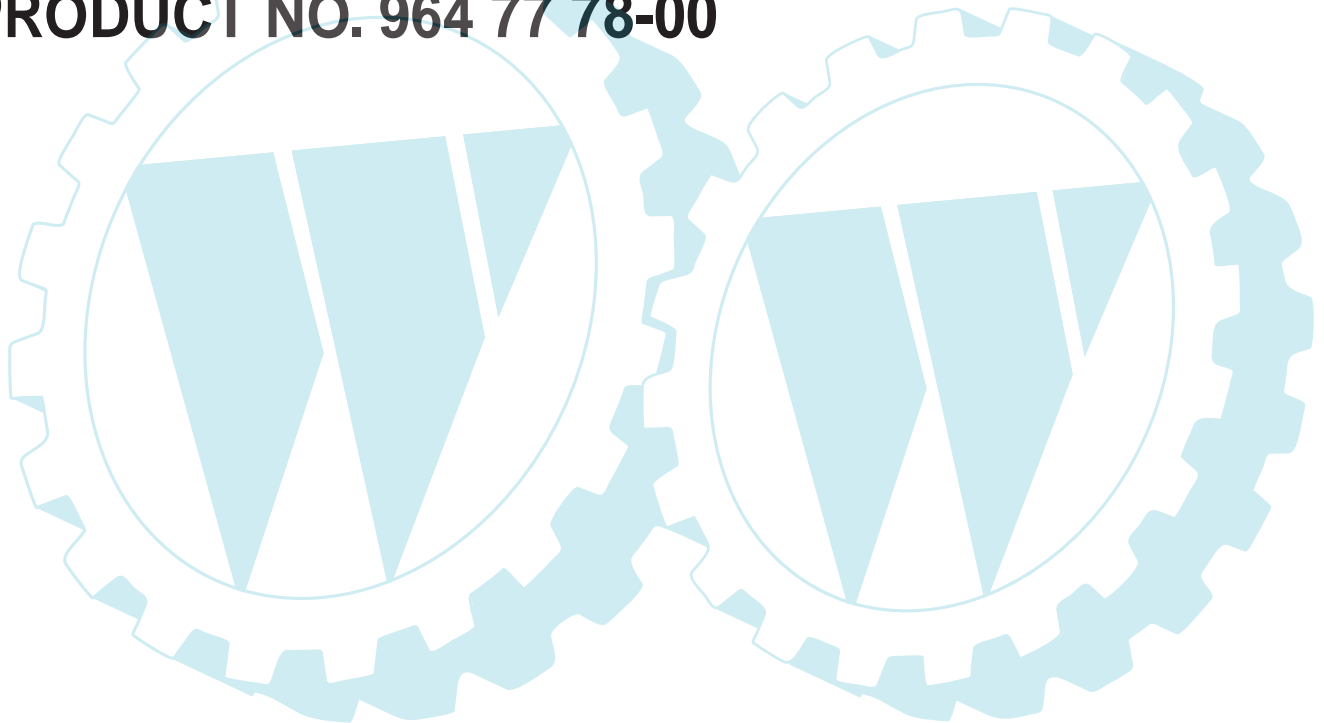

**TRACTOR - MODEL NO. P145PH107 (P145PH107B), PRODUCT NO. 964 77 78-00
SCHEMATIC**

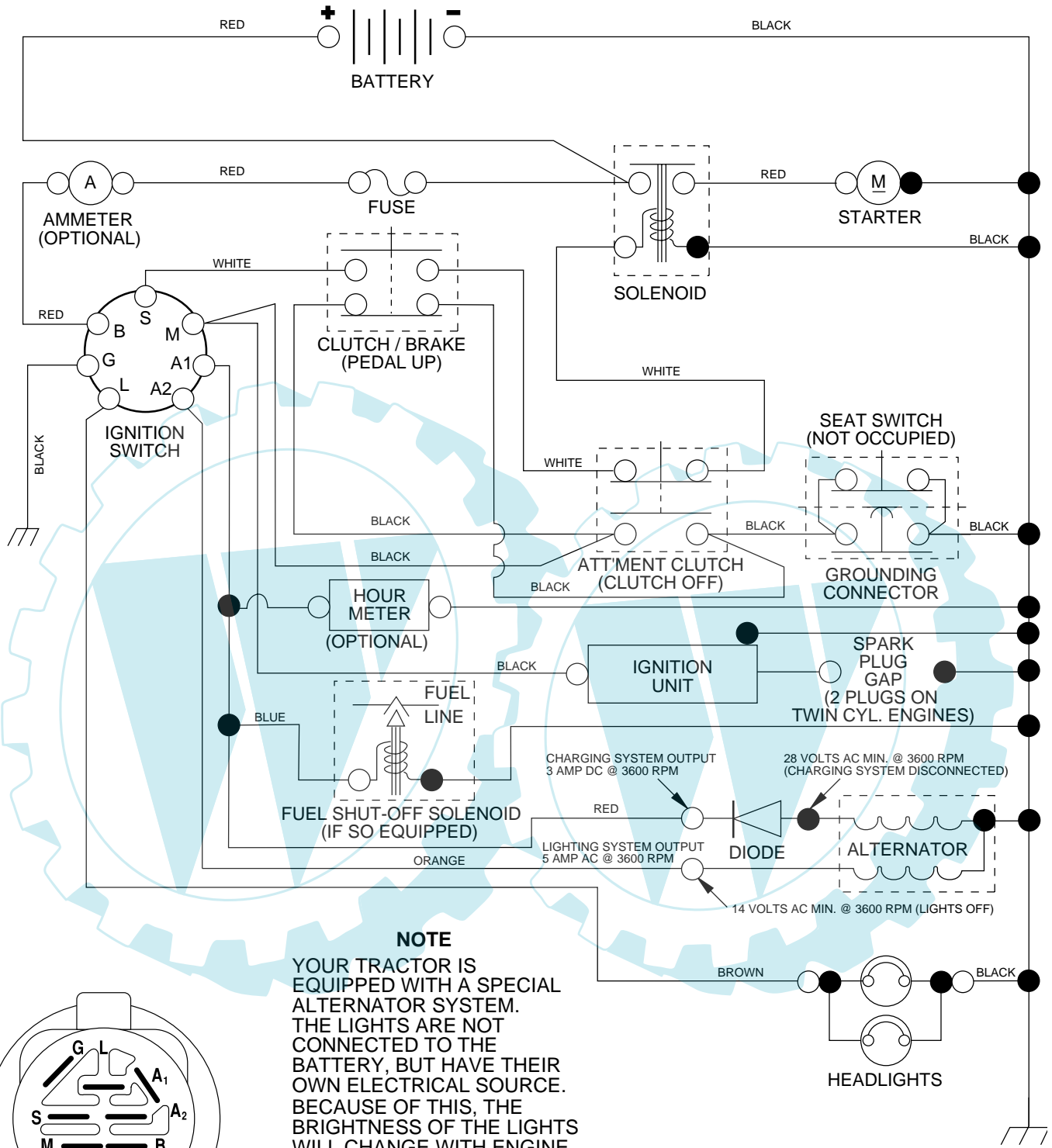

NOTE

YOUR TRACTOR IS EQUIPPED WITH A SPECIAL ALTERNATOR SYSTEM. THE LIGHTS ARE NOT CONNECTED TO THE BATTERY, BUT HAVE THEIR OWN ELECTRICAL SOURCE. BECAUSE OF THIS, THE BRIGHTNESS OF THE LIGHTS WILL CHANGE WITH ENGINE SPEED. AT IDLE THE LIGHTS WILL DIM. AS THE ENGINE IS SPEEDED UP, THE LIGHTS WILL BECOME THEIR BRIGHTEST.

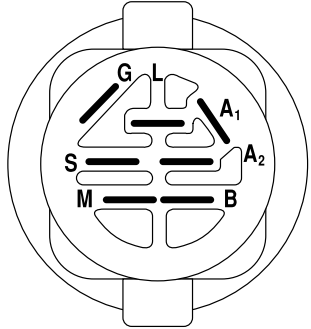

IGNITION SWITCH

POSITION	CIRCUIT	"MAKE"
OFF	M+G+A1	NONE
RUN/LIGHT	B+A1	A2+L
RUN	B+A1	NONE
START	B + S + A1	NONE

WIRING INSULATED CLIPS

NOTE: IF WIRING INSULATED CLIPS WERE REMOVED FOR SERVICING OF UNIT, THEY SHOULD BE REPLACED TO PROPERLY SECURE YOUR WIRING.

02363

REPAIR PARTS

TRACTOR - MODEL NO. P145PH107 (P145PH107B), PRODUCT NO. 964 77 78-00
ELECTRICAL

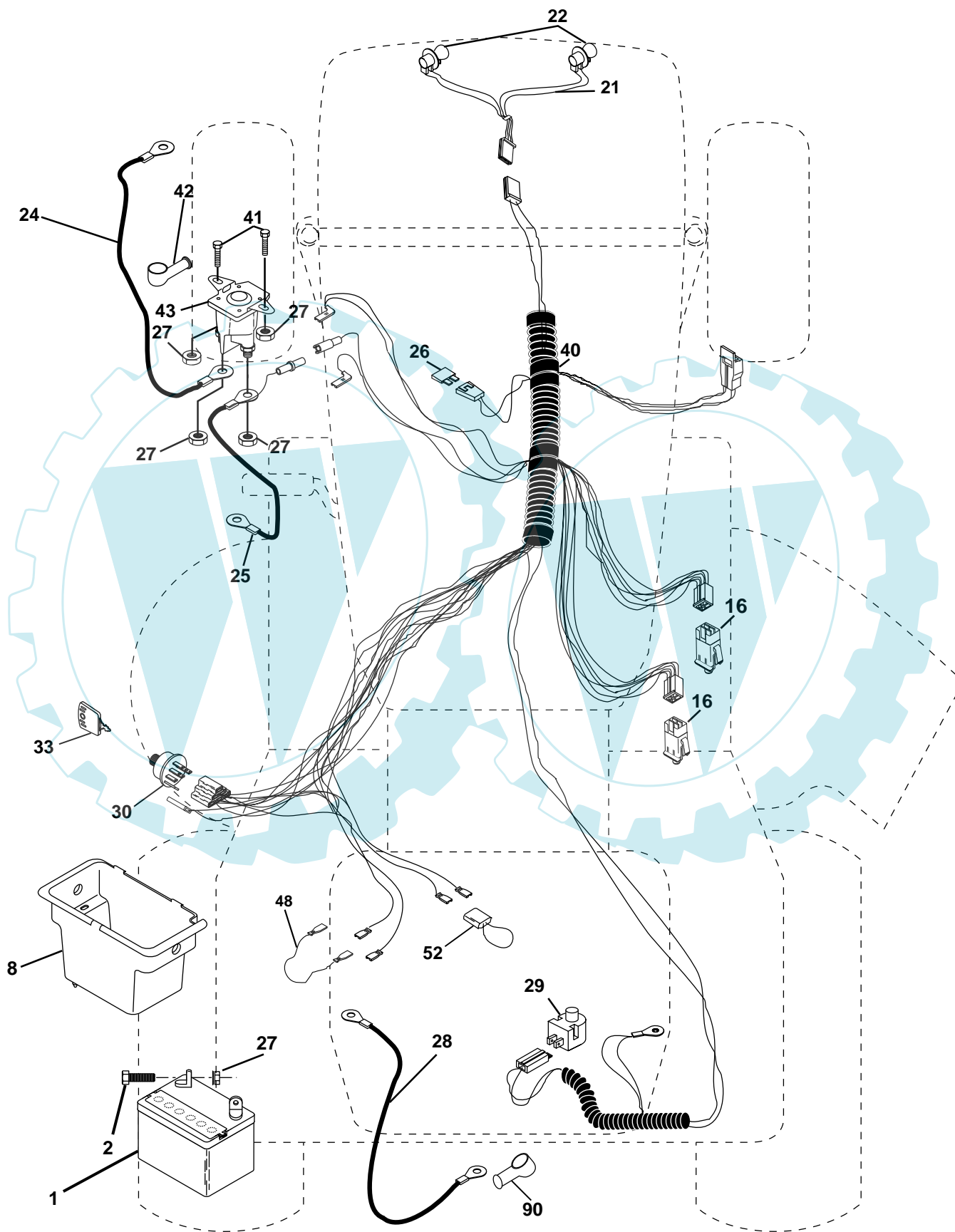

REPAIR PARTS

TRACTOR - MODEL NO. P145PH107 (P145PH107B), PRODUCT NO. 964 77 78-00
ELECTRICAL

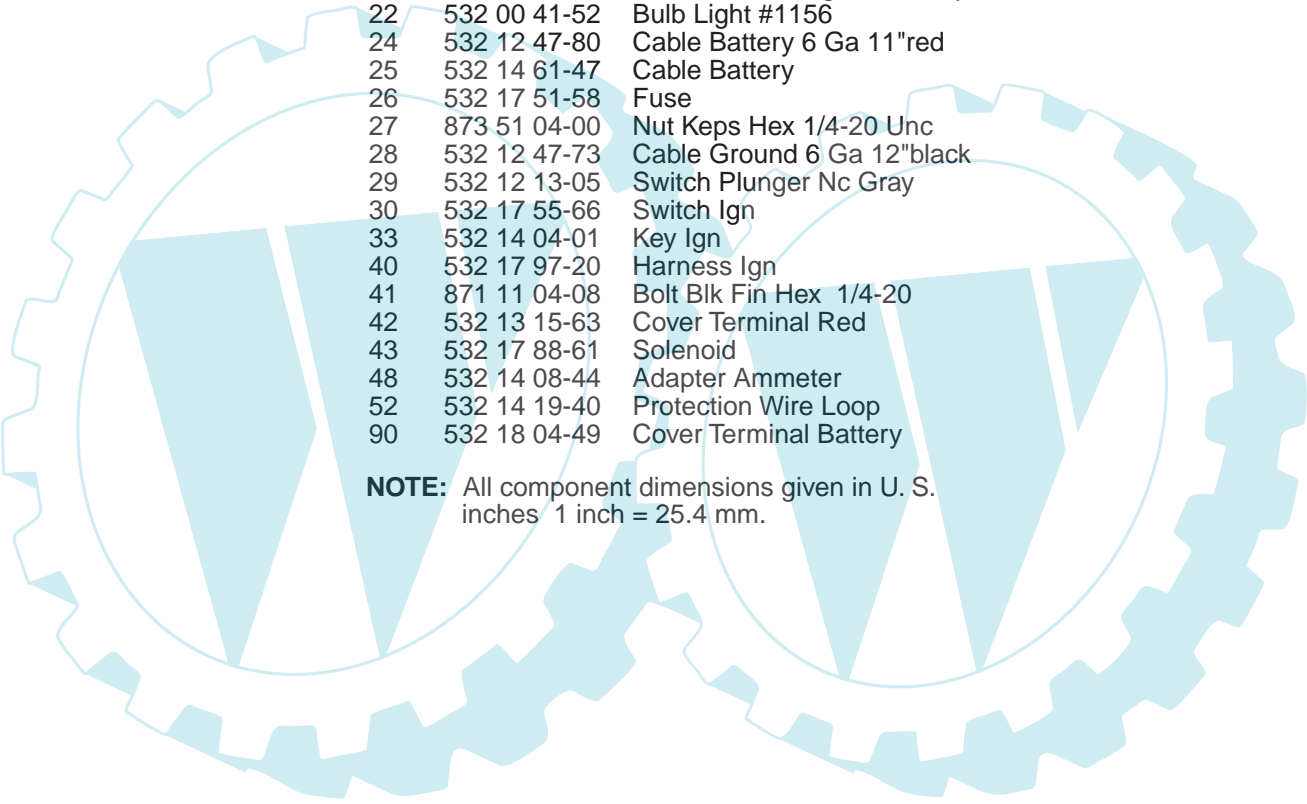

KEY NO.	PART NO.	DESCRIPTION
1	532 16 34-65	Battery 12 Volt 25 Amp
2	874 76 04-12	Bolt Hex Hd 1/4-20unc X 3/4
8	532 17 66-89	Battery Box
16	532 17 61-38	Switch Interlock Push-In
21	532 17 56-88	Harness Asm Light W/4152j
22	532 00 41-52	Bulb Light #1156
24	532 12 47-80	Cable Battery 6 Ga 11"red
25	532 14 61-47	Cable Battery
26	532 17 51-58	Fuse
27	873 51 04-00	Nut Keps Hex 1/4-20 Unc
28	532 12 47-73	Cable Ground 6 Ga 12"black
29	532 12 13-05	Switch Plunger Nc Gray
30	532 17 55-66	Switch Ign
33	532 14 04-01	Key Ign
40	532 17 97-20	Harness Ign
41	871 11 04-08	Bolt Blk Fin Hex 1/4-20
42	532 13 15-63	Cover Terminal Red
43	532 17 88-61	Solenoid
48	532 14 08-44	Adapter Ammeter
52	532 14 19-40	Protection Wire Loop
90	532 18 04-49	Cover Terminal Battery

NOTE: All component dimensions given in U. S. inches 1 inch = 25.4 mm.

REPAIR PARTS

TRACTOR - MODEL NO. P145PH107 (P145PH107B), PRODUCT NO. 964 77 78-00

CHASSIS

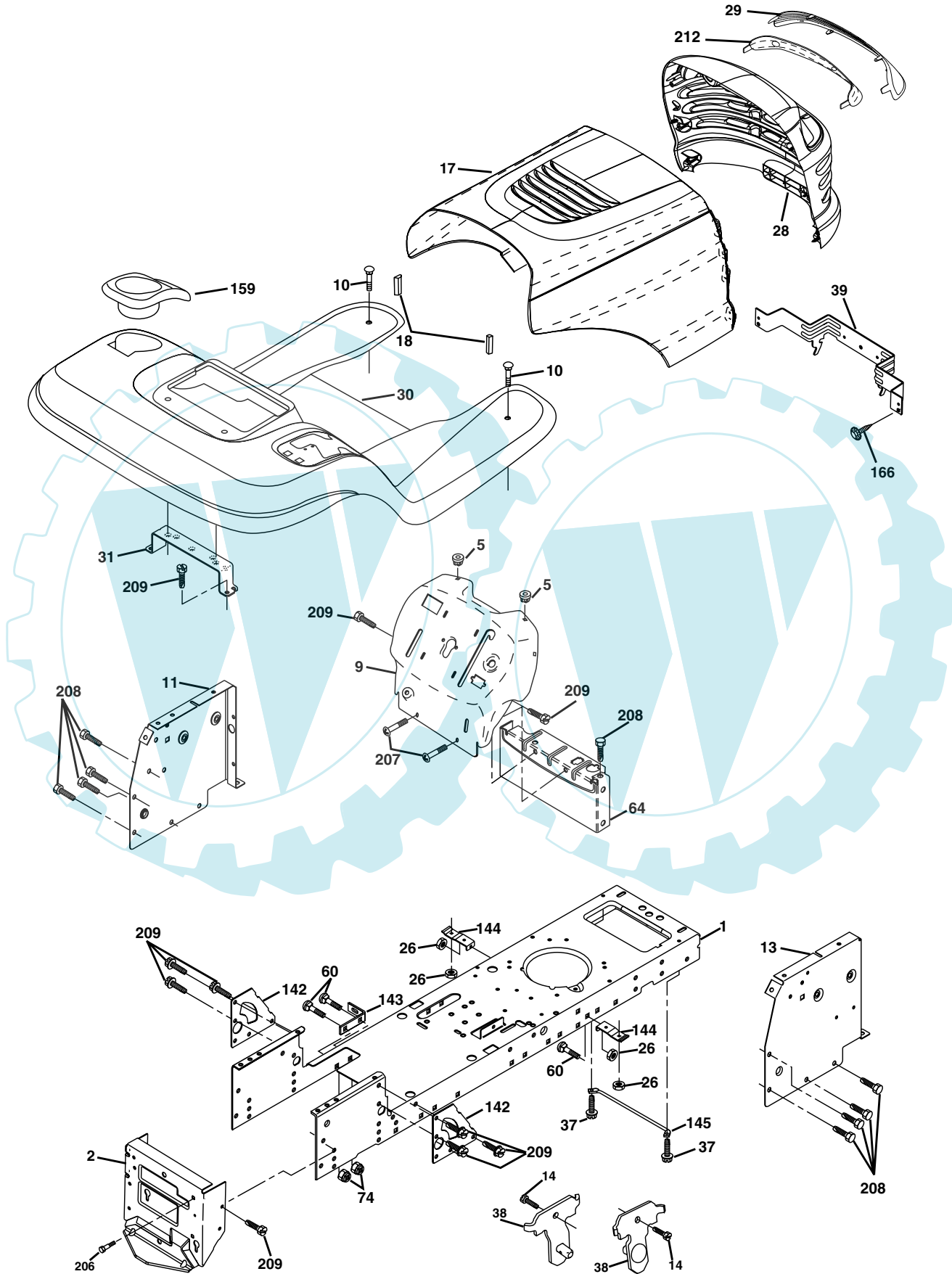

chassis-Laser -lt.stlt_30

REPAIR PARTS

TRACTOR - MODEL NO. P145PH107 (P145PH107B), PRODUCT NO. 964 77 78-00
CHASSIS

KEY NO.	PART NO.	DESCRIPTION
1	532 17 46-19	Chassis
2	532 17 65-54	Drawbar
5	532 15 52-72	Bumper Hood Dash
9	532 18 94-12	Dash
10	872 14 06-08	Bolt Rdhd Sqnk 3/8-16unc X 1
11	532 17 49-96	Panel Dash LH
13	532 18 17-19	Panel Dash RH
14	817 49 06-08	Screw Thdrol 3/8-16 x 1/2
17	532 18 27-16	Hood
18	532 18 49-21	Bumper Hood
26	873 80 06-00	Nut Lock Hex w/Ins 3/8-16 Unc
28	532 17 97-49	Grille/Lens Asm
29	532 18 27-18	Lens Grille
30	532 18 65-66	Fender
31	532 13 99-76	Bracket Fender
37	817 49 05-08	Screw Thdrol 5/16-18 x 1/2 Tyt
38	532 17 57-10	Bracket Asm Pivot Mower Rear
39	532 17 47-14	Bracket Pivot Laser
60	872 14 06-06	Bolt RdHd Sqnk 3/8-16 Unc x 3/4
64	532 15 47-98	Dash Lower STLT
74	873 68 06-00	Nut Crownlock 3/8-16
142	532 17 57-02	Plate Reinforcement STLT
143	532 18 66-89	Bracket Swaybar
144	532 17 55-82	Bracket Footrest
145	532 15 65-24	Rod Pivot Chassis/Hood
159	532 18 13-55	Cupholder
166	532 19 16-11	Screw #10 x 3/4 Single Lead-Hex
206	532 17 01-65	Bolt Shoulder 5/16-18
207	817 67 05-08	Screw Thdrol 5/16-18 x 1/2
208	817 67 06-08	Screw Thdrol 3/8-16 x 1/2
209	817 00 06-12	Screw 3/8-16 x 3/4
212	532 17 51-43	Insert Lens Reflective

NOTE: All component dimensions given in U.S. inches
1 inch = 25.4 mm.

REPAIR PARTS

TRACTOR - MODEL NO. P145PH107 (P145PH107B), PRODUCT NO. 964 77 78-00
DRIVE

KEY NO.	PART NO.	DESCRIPTION	KEY NO.	PART NO.	DESCRIPTION
1	-----	Transaxle (Order parts from trans- axle manufacturer)	95	532 18 08-25	Rod Bypass
		Hydro gear Model 336-0510	96	532 12 47-88	Retainer Spring
6	817 06 05-12	Screw 5/16-18	116	872 14 06-08	Bolt RDHD SQNK 3/8-16 unc x 1
15	874 49 05-44	Bolt Hex Flghd 5/16-18 Gr. 5	120	873 90 06-00	Nut Lock Flg 3/8-16 Unc
16	873 80 05-00	Nut Lock Hex W/Ins. 5/16-18 unc	150	532 17 54-56	Spacer Retainer
19	873 80 06-00	Nut Lock Hex W/Wsh 3/8-16 unc	151	819 13 32-10	Washer 13/32 x 2 x 10 Ga.
21	532 18 65-71	Knob Custom Control Cruise	202	872 11 06-14	Bolt Carr Sh 3/8-16 x 1-3/4 Gr. 5
22	532 17 58-96	Rod, Brake	207	817 06 05-16	Screw 5/16-18 x 1
24	873 35 06-00	Nut, Hex Jam 3/8-16 unc	212	532 14 52-12	Nut HexFlange Lock
25	532 10 68-88	Spring, Brake Rod	214	532 17 47-35	Link Transaxle
26	819 13 13-16	Washer	215	532 17 56-46	Cover Pedal Forward
27	876 02 04-12	Pin Cotter 1/8 x 3/4 CAD.	217	532 17 94-33	Pedal Reverse
28	532 17 57-65	Rod, Parking Brake	218	532 17 47-13	Arm Control Pedal Reverse
29	532 07 16-73	Cap, Brake, Park	219	532 17 48-39	Bracket Frest PdL Ctrl. Hyd
30	532 16 95-92	Bracket, Transaxle	220	532 17 47-11	Bracket Mtg. Pedal Control
32	874 76 05-12	Bolt Hex Hd 5/16-18 unc x 3/4	221	872 14 06-06	Bolt Rdhd Sqnk 3/8-16 unc x 3/4
33	872 14 05-06	Bolt Rdhd Sqnk 5/16-18 unc x 3/4	222	873 68 07-00	Nut Crownlock 7/16-14 unc
34	532 17 55-78	Shaft, Foot Pedal	223	532 17 48-40	Washer Nylon 11/16 ID x .060
35	532 12 01-83	Bearing, Nylon	224	532 17 47-36	Pedal Forward
36	819 21 16-16	Washer	225	532 17 47-12	Arm Control Pedal Forward
37	532 12 49-63	Pin, Roll	226	532 17 49-02	Bolt Pivot Spacer
38	532 17 91-14	Pulley, Composite	227	532 17 47-10	Cam Reverse Pedal LT
39	872 11 06-22	Bolt 3/8-16 x 2-3/4 Gr. 5	228	532 17 90-32	Bolt Shoulder 5/16-18
41	532 17 55-56	Keeper, Belt Idler Flat	229	532 17 64-51	Washer Serrated 5/16 x .75
47	532 12 77-83	Pulley, Idler, V-Groove	231	532 17 45-73	Strap Torque
48	532 15 44-07	Bellcrank Clutch Grnd Drw Stl	232	532 17 55-70	Actuator Cruise Disengage
49	532 12 32-05	Retainer, Belt	233	532 17 48-56	Pawl Control Cruise
50	872 11 06-12	Bolt Carr. SH 3/8-16 x 1-1/2 Gr. 5	234	532 17 48-58	Lever Control Cruise
51	873 68 06-00	Nut Crownlock 3/8-16 unc	235	532 17 48-57	Sector Control Cruise
52	873 68 05-00	Nut, Crownlock 5/16-18 unc	236	532 12 89-03	Bolt Shoulder 3/8-16 Unc 1/44
53	532 10 57-10	Link, Clutch	237	532 17 01-65	Bolt Shoulder 5/16-18
55	532 10 57-09	Spring, Return, Clutch	238	532 17 58-07	Arm Mtg. Cruise Sector
57	532 14 02-94	V-Belt, Ground Drive	239	817 49 05-08	Screw Thdrol 5/16 x 1/2
59	532 16 96-91	Keeper, Center Span	240	532 17 56-10	Spring Return Cruise Control
61	817 12 06-14	Screw 3/8-16 x .875	241	873 93 04-00	Nut Centerlock 1/4-20 unc
62	532 12 35-33	Cover, Pedal	242	874 78 04-12	Bolt Fin Hex 1/4-20 Unc x .75
63	532 18 02-19	Pulley, Engine	243	532 18 02-18	Bracket Belt Guide
64	532 17 39-37	Bolt Hex 7/16-20 x 4 Gr. 5	244	817 49 05-10	Screw 5/16-18 x 5/8
65	810 04 07-00	Washer	250	817 06 06-12	Screw 3/8-16 x 3/4
66	532 15 47-78	Keeper Belt Engine	253	532 17 94-22	Washer .312 x .615 x 16 Ga.
74	532 13 70-57	Spacer, Axle	254	532 17 80 62	Clip Retainer
75	532 12 17-49	Washer 25/32 x 1-1/4 x 16 Ga.	263	817 00 06-12	Screw Hex Wsh Thdr. 3/8-16 x 3/4
76	812 00 00-01	E-Ring	268	532 18 24-02	Guard Muffler RH
77	532 12 35-83	Key, Square	275	819 13 16-14	Washer 13/32 x 1 x 14 Ga.
78	532 12 17-48	Washer 25/32 x 1-5/8 x 16 Ga.			
89	532 18 14-53	Console, Shift			
90	532 12 43-46	Nut Self-Thd Wsh-hd 1/4 Zinc			

NOTE: All component dimensions given in U.S. inches
1 inch = 25.4 mm

REPAIR PARTS

TRACTOR - MODEL NO. P145PH107 (P145PH107B), PRODUCT NO. 964 77 78-00
STEERING

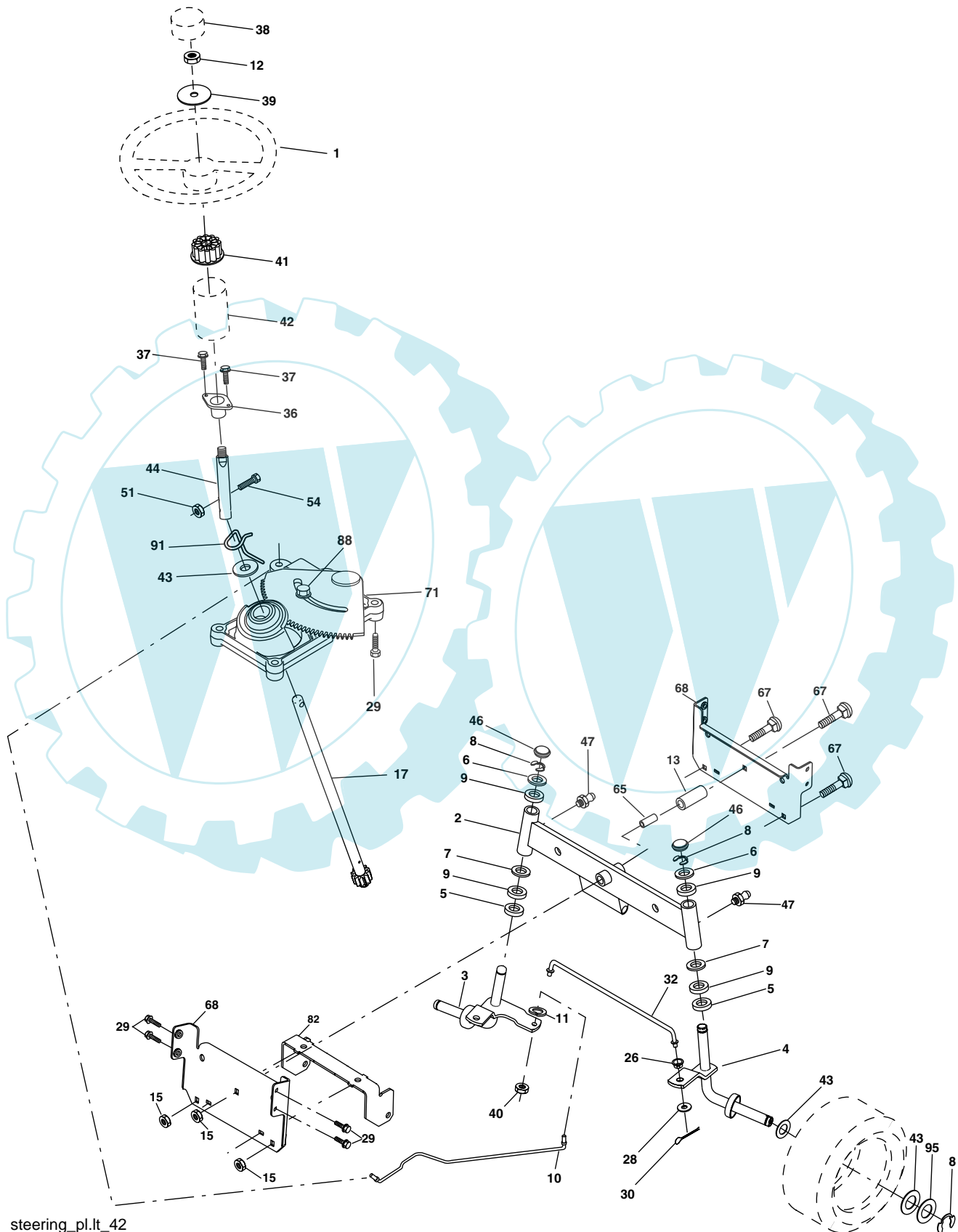

steering_pl.lt_42

REPAIR PARTS

TRACTOR - MODEL NO. P145PH107 (P145PH107B), PRODUCT NO. 964 77 78-00
STEERING

KEY NO.	PART NO.	DESCRIPTION
1	532 18 59-58	Wheel Steering
2	532 17 51-31	Axle Asm Fr
3	532 16 98-40	Spindle Asm LH
4	532 16 98-39	Spindle Asm RH
5	532 12 49-31	Bearing Race Thrust Harden
6	532 12 17-48	Washer 25/32 x 1-5/8 x 16 Ga
7	819 27 20-16	Washer 27/32 x 1-1/4 x 16 Ga
8	812 00 00-29	Ring Klip #t5304-75
9	532 12 49-37	Bearing Col Strg Blk
10	532 17 51-21	Link Drag
11	810 04 06-00	Washer Lock Hvy Hlcl Spr 3/8
12	873 94 08-00	Nut Hex Jam Toplock 1/2-20 UNF
13	532 13 65-18	Spacer Brace Axle
15	532 14 52-12	Nut Hexflange Lock
17	532 18 06-41	Shaft Asm Strg
26	532 12 68-47	Bushing Link Drag Blk LR
28	819 13 14-16	Washer 13/32 x 7/8 x 16 Ga
29	817 00 06-12	Screw 3/8-16 x .75
30	876 02 04-12	Pin Cotter 1/8 x 3/4 Cad
32	532 13 04-65	Rod Tie Wire Form 19 75 Mech
36	532 15 50-99	Bushing Strg Nat .623/.618ld
37	532 15 29-27	Screw TT #10-32 x 5 x 3/8 Flange
38	532 17 20-93	Cap Wheel Steer
39	819 18 24-11	Washer 9/16 x 1-1/2 11 Ga.
40	873 54 06-00	Nut Crownlock 3/8-24
41	532 15 99-45	Adaptor Wheel Strg
42	532 16 96-33	Boot Shaft Steering
43	532 12 17-49	Washer 25/32 X 1 1/4 X 16 Ga
44	532 18 06-40	Extension Steering
46	532 12 12-32	Cap Spindle Fr Top Blk
47	532 18 32-26	Fitting Grease
51	873 54 04-00	Nut Crownlock 1/4-28
54	871 13 04-20	Bolt Hex 1/4-28 UNF x 1-1/4 Gr. 8
65	532 16 03-67	Spacer Brace Axle
67	872 14 06-18	Bolt RDHD SQ 3/8-16 UNC x 2-1/4
68	532 16 98-27	Brace Axle
71	532 17 51-46	Steering Asm.
82	532 16 98-35	Bracket Susp. Chassis Front
88	532 17 51-18	Bolt Shoulder 7/16-20
91	532 17 55-53	Clip Steering
95	532 18 89-67	Washer Hardened

NOTE: All component dimensions given in U.S. inches
1 inch = 25.4 mm.

REPAIR PARTS

TRACTOR - MODEL NO. P145PH107 (P145PH107B), PRODUCT NO. 964 77 78-00
ENGINE

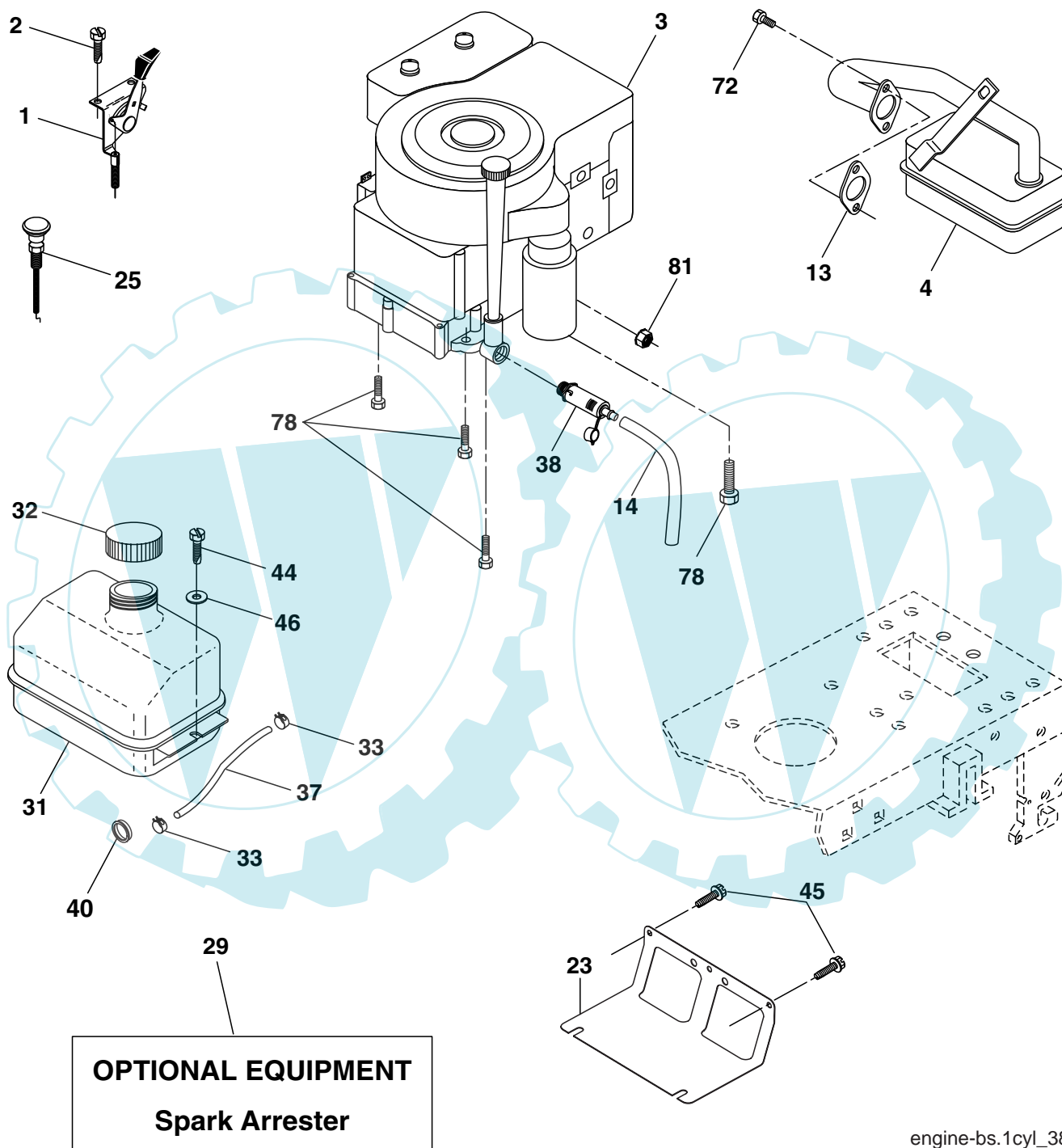

engine-bs.1cyl_38

REPAIR PARTS

TRACTOR - MODEL NO. P145PH107 (P145PH107B), PRODUCT NO. 964 77 78-00
ENGINE

KEY NO.	PART NO.	DESCRIPTION
1	532 17 05-51	Control Throttle/Choke Flag Eec
2	817 72 04-08	Screw Hex Thd Cut 1/4-20 x 1/2
3	-----	Engine Briggs & Stratton 282H07 (Order parts from engine manufacturer)
4	532 13 73-52	Muffler
13	532 16 52-91	Gasket Eng
14	532 14 84-56	Tube Drain Oil Easy
23	532 16 98-37	Shield Brn/Dbt Guard
25	532 19 06-95	Control Choke
29	532 13 71-80	Kit Spark Arrecter
31	532 18 49-00	Tank Fuel Front 1.25
32	532 14 05-27	Cap Asm Fuel W/sym Vented
33	532 12 34-87	Clamp Hose Blk
37	532 13 70-40	Line Fuel 20"
38	532 18 16-54	Plug Drain Oil Easy
40	532 12 40-28	Bushing Snap Nyl Blk Fuel Line
44	817 67 04-12	Screw Hexwsh Thdrol 1/4-20 x 3/4
45	817 00 06-12	Screw Hexwsh Thdrol 3/8-16 x 3/4
46	819 09 14-16	Washer 9/32 x 7/8 x 16 Ga.
72	532 18 39-06	Screw Socket Head 5/16-18 x 1
78	817 06 06-20	Screw 3/8-16 x 1-1/4
81	873 51 04-00	Nut Keps Hex 1/4-20 unc

NOTE: All component dimensions given in U.S. inches
1 inch = 25.4 mm

REPAIR PARTS

TRACTOR - MODEL NO. P145PH107 (P145PH107B), PRODUCT NO. 964 77 78-00
SEAT

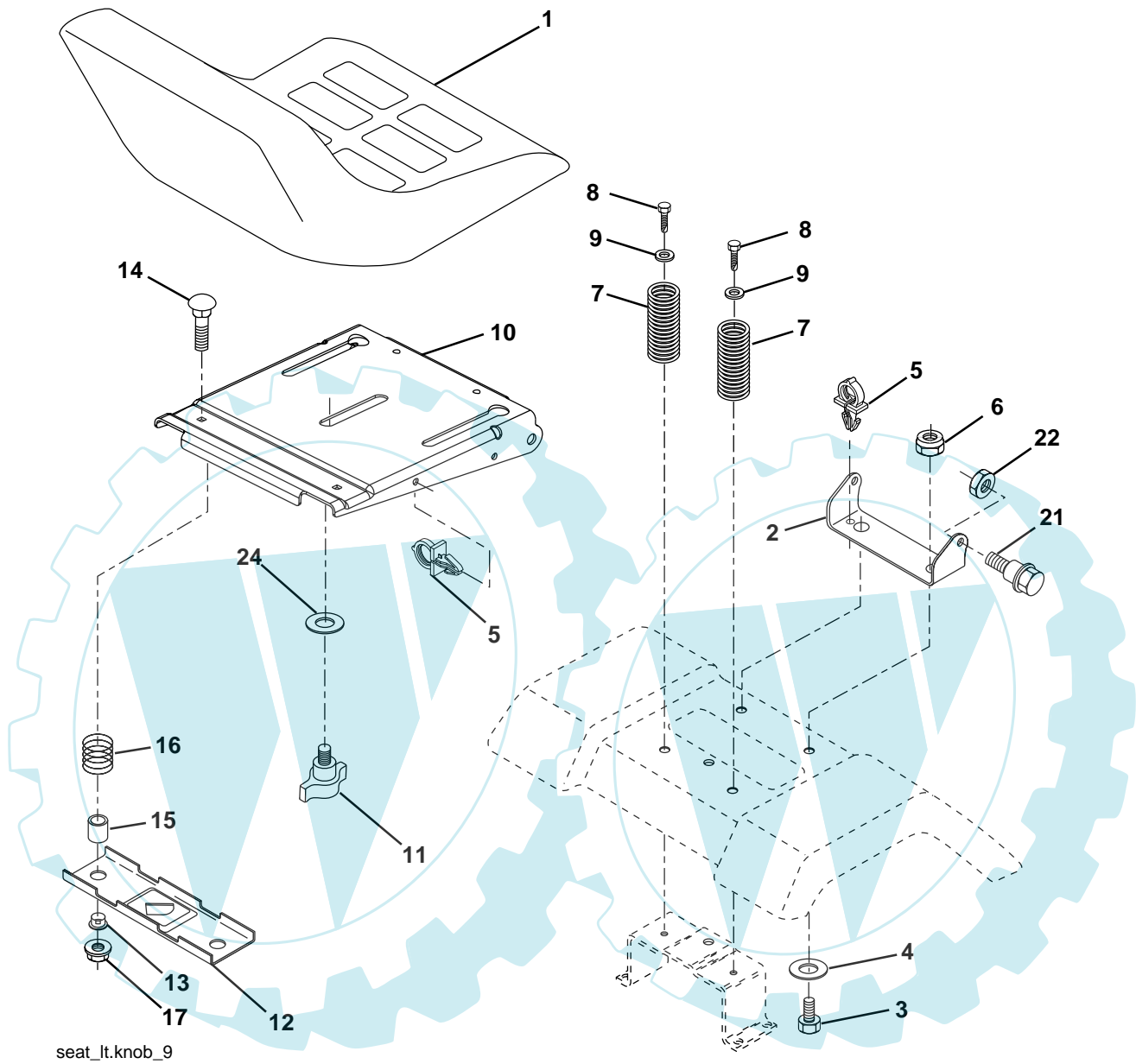

seat_lt.knob_9

KEY NO.	PART NO.	DESCRIPTION
1	532 18 87-05	Seat
2	532 18 01-66	Bracket Pivot Seat
3	871 11 06-16	Bolt Fin Hex 3/8-16 unc x 1
4	819 13 16-10	Washer 13/32 x 1 x 10 Ga.
5	532 14 50-06	Clip Push-In
6	873 80 06-00	Nut Lock Hex w/Wsh 3/8-16 unc
7	532 12 41-81	Spring Seat Cprsn 2 250 Blk Zi
8	817 00 06-16	Screw 3/8-16 x 1.5
9	819 13 16-14	Washer 13/32 x 1 x 14 Ga.
10	532 18 01-86	Pan Seat
11	532 16 63-69	Knob Seat
12	532 12 12-46	Bracket Mounting Switch
13	532 12 12-48	Bushing Snap Blk Nyl 50 Id

KEY NO.	PART NO.	DESCRIPTION
14	872 05 04-12	Bolt Rdhd Sht Nk 1/4-20 x 1-1/2
15	532 13 43-00	Spacer Split 28x 96 Yel Zinc
16	532 12 12-50	Spring Cprsn 1 27 Blk Pnt
17	532 12 39-76	Nut Lock 1/4 Lge Flg Gr. 5 Zinc
21	532 17 18-52	Bolt Shoulder 5/16-18 unc -2A
22	873 80 05-00	Nut Lock Hex W/Insert 5/16-18 unc
24	819 17 19-12	Washer 17/32 x 1-3/16 x 12 Ga.

NOTE: All component dimensions given in U.S. inches.
1 inch = 25.4 mm

REPAIR PARTS

TRACTOR - MODEL NO. P145PH107 (P145PH107B), PRODUCT NO. 964 77 78-00
DECALS

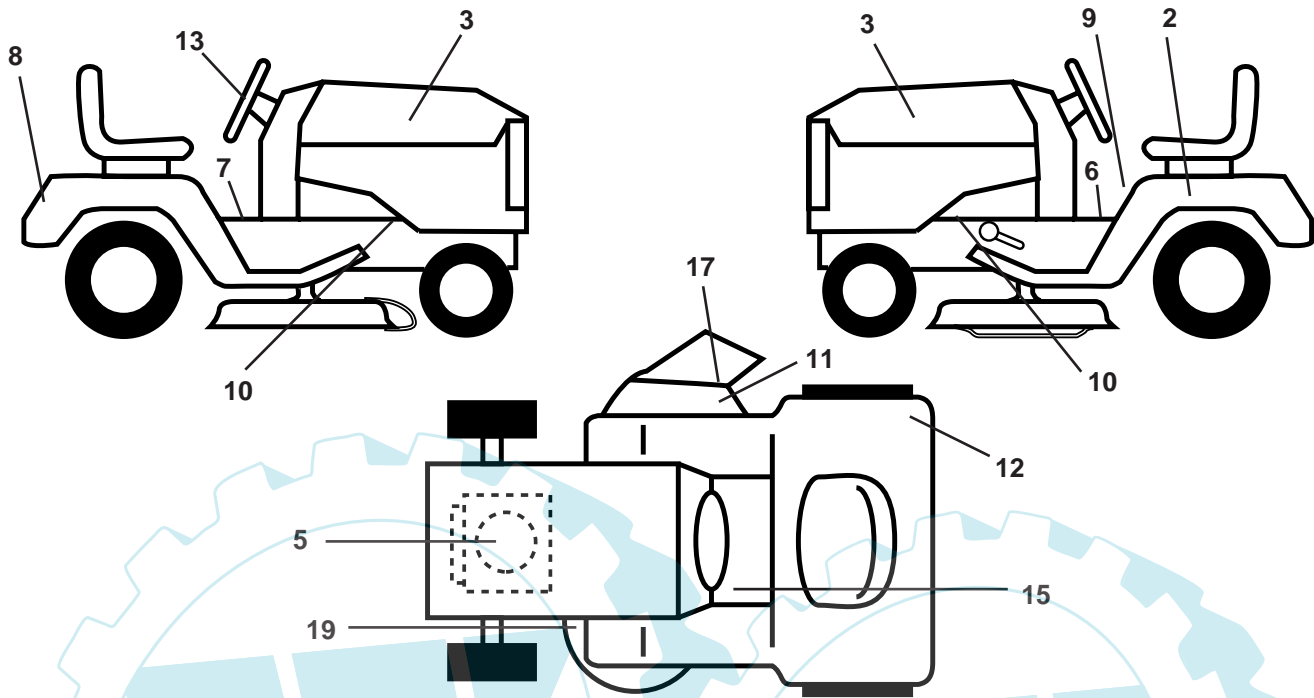

KEY NO.	PART NO.	DESCRIPTION
2	532 14 50-05	Decal Bat Dan/Poi P/L Symbols
3	532 18 96-24	Decal Hood
5	532 18 47-67	Decal Engine
6	532 17 83-02	Decal Operator Cruise
7	532 14 08-37	Decal Saddle Brake Parking
8	532 18 89-94	Decal Fender
9	532 14 54-98	Decal Read Owners Manual Syms
10	532 15 97-36	Decal Chassis Hot Muffler
11	532 18 21-66	Decal Mower Cut finger Symbol
12	532 18 04-32	Decal 100 Db
13	532 18 58-85	Decal Steering Wheel

KEY NO.	PART NO.	DESCRIPTION
15	532 15 97-37	Decal Brake/Clutch
17	532 17 91-28	Decal Deck "B"
19	532 16 03-96	Decal V-Belt Sch
--	532 16 25-98	Decal Drawbar Load Limit
--	532 13 83-11	Decal Lift Handle (Lift Handle)
--	532 19 17-86	Pad, Footrest RH
--	532 19 17-87	Pad, Footrest LH
--	532 16 69-60	Decal, By-Pass
--	532 19 17-32	Manual Operator's Euro
--	532 19 17-34	Manual Operator's Scan

WHEELS & TIRES

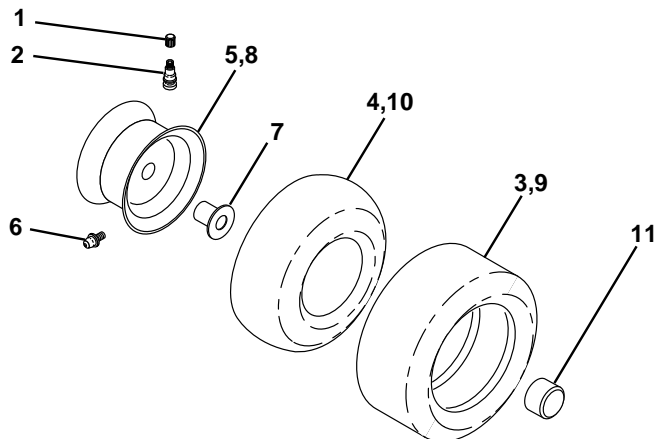

KEY NO.	PART NO.	DESCRIPTION
1	532 05 91-92	Cap Valve Tire
2	532 06 51-39	Stem Valve
3	532 10 62-22	Tire F Ts 15 X 6 0 - 6 Service
4	532 05 99-04	Tube Front (Service Item Only)
5	532 12 51-21	Rim Asm 6" front Service
6	532 12 49-57	Fitting Grease (Front Wheel Only)
7	532 12 49-59	Bearing Flange (Front Wheel Only)
8	532 12 51-22	Rim Asm 8" rear Service
9	532 12 20-82	Tire R Ts 20 x 10-8 C. Service
10	532 12 49-26	Tube Rear (Service Item Only)
11	532 17 50-39	Cap Axle Blk 1 50 X 1 00

NOTE: All component dimensions given in U.S. inches
1 inch = 25.4 mm

REPAIR PARTS

TRACTOR - MODEL NO. P145PH107 (P145PH107B), PRODUCT NO. 964 77 78-00
MOWER LIFT

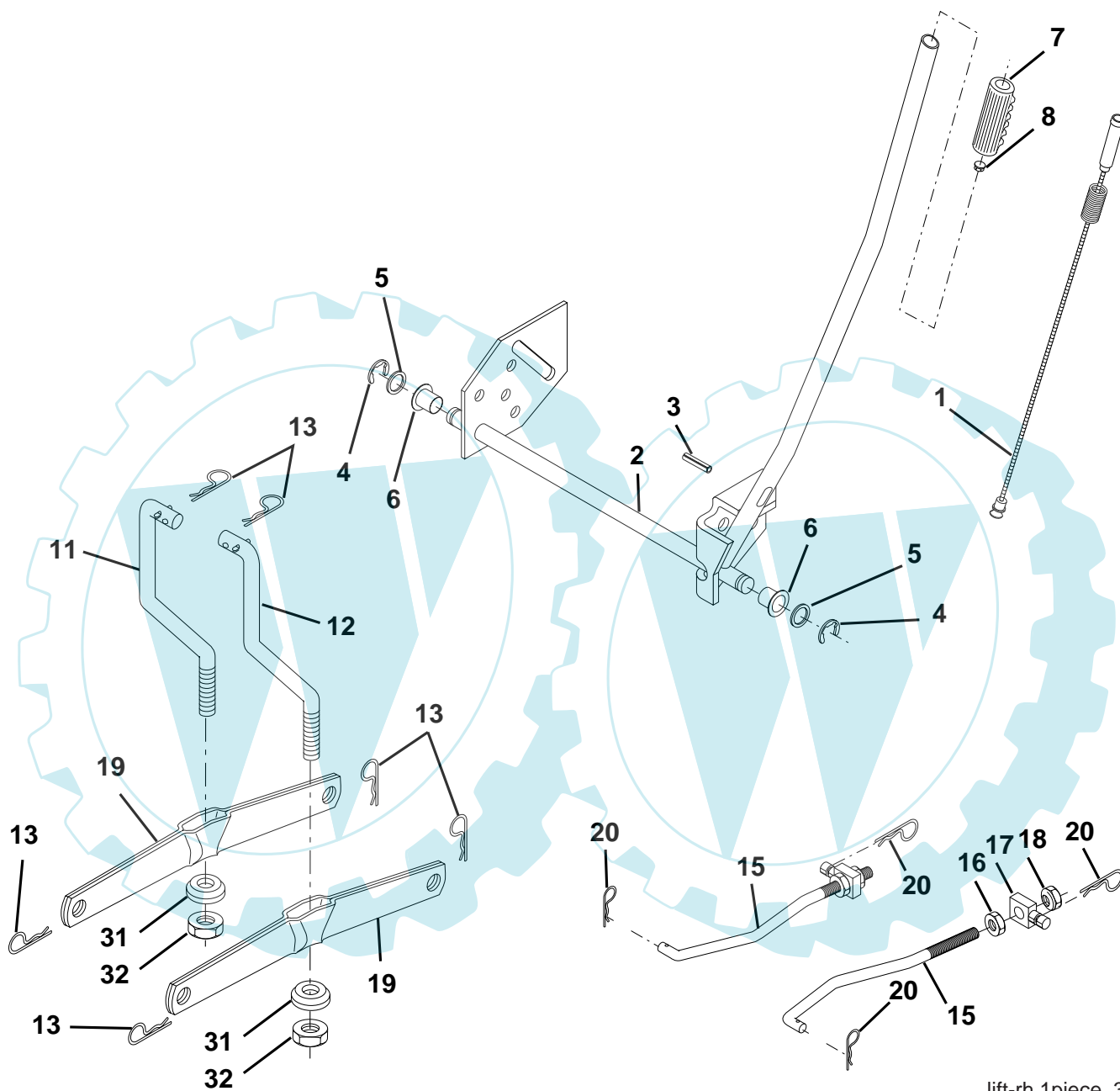

lift-rh.1piece_3

REPAIR PARTS

TRACTOR - MODEL NO. P145PH107 (P145PH107B), PRODUCT NO. 964 77 78-00
MOWER LIFT

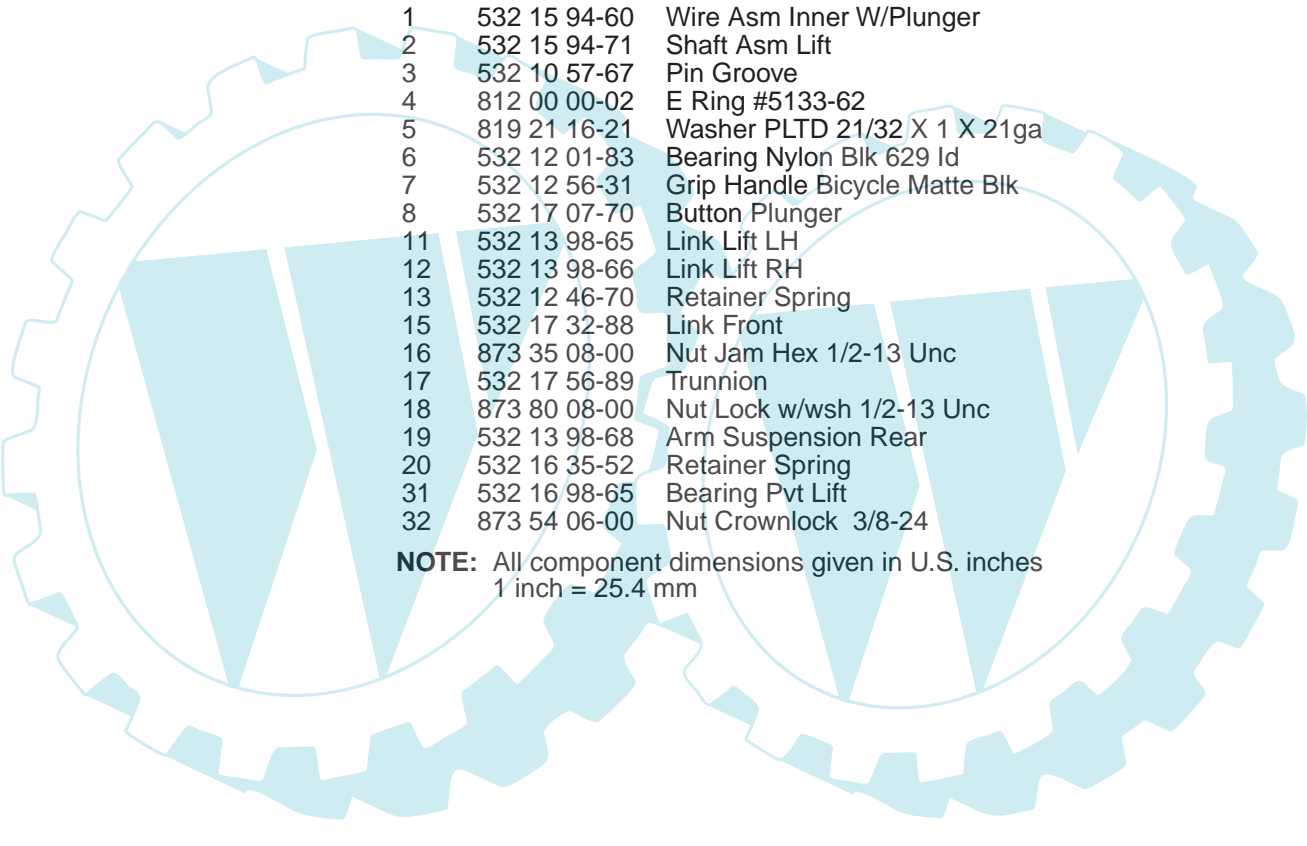

KEY NO.	PART NO.	DESCRIPTION
1	532 15 94-60	Wire Asm Inner W/Plunger
2	532 15 94-71	Shaft Asm Lift
3	532 10 57-67	Pin Groove
4	812 00 00-02	E Ring #5133-62
5	819 21 16-21	Washer PLTD 21/32 X 1 X 21ga
6	532 12 01-83	Bearing Nylon Blk 629 Id
7	532 12 56-31	Grip Handle Bicycle Matte Blk
8	532 17 07-70	Button Plunger
11	532 13 98-65	Link Lift LH
12	532 13 98-66	Link Lift RH
13	532 12 46-70	Retainer Spring
15	532 17 32-88	Link Front
16	873 35 08-00	Nut Jam Hex 1/2-13 Unc
17	532 17 56-89	Trunnion
18	873 80 08-00	Nut Lock w/wsh 1/2-13 Unc
19	532 13 98-68	Arm Suspension Rear
20	532 16 35-52	Retainer Spring
31	532 16 98-65	Bearing Pvt Lift
32	873 54 06-00	Nut Crownlock 3/8-24

NOTE: All component dimensions given in U.S. inches
1 inch = 25.4 mm

REPAIR PARTS

TRACTOR - MODEL NO. P145PH107 (P145PH107B), PRODUCT NO. 964 77 78-00
MOWER DECK

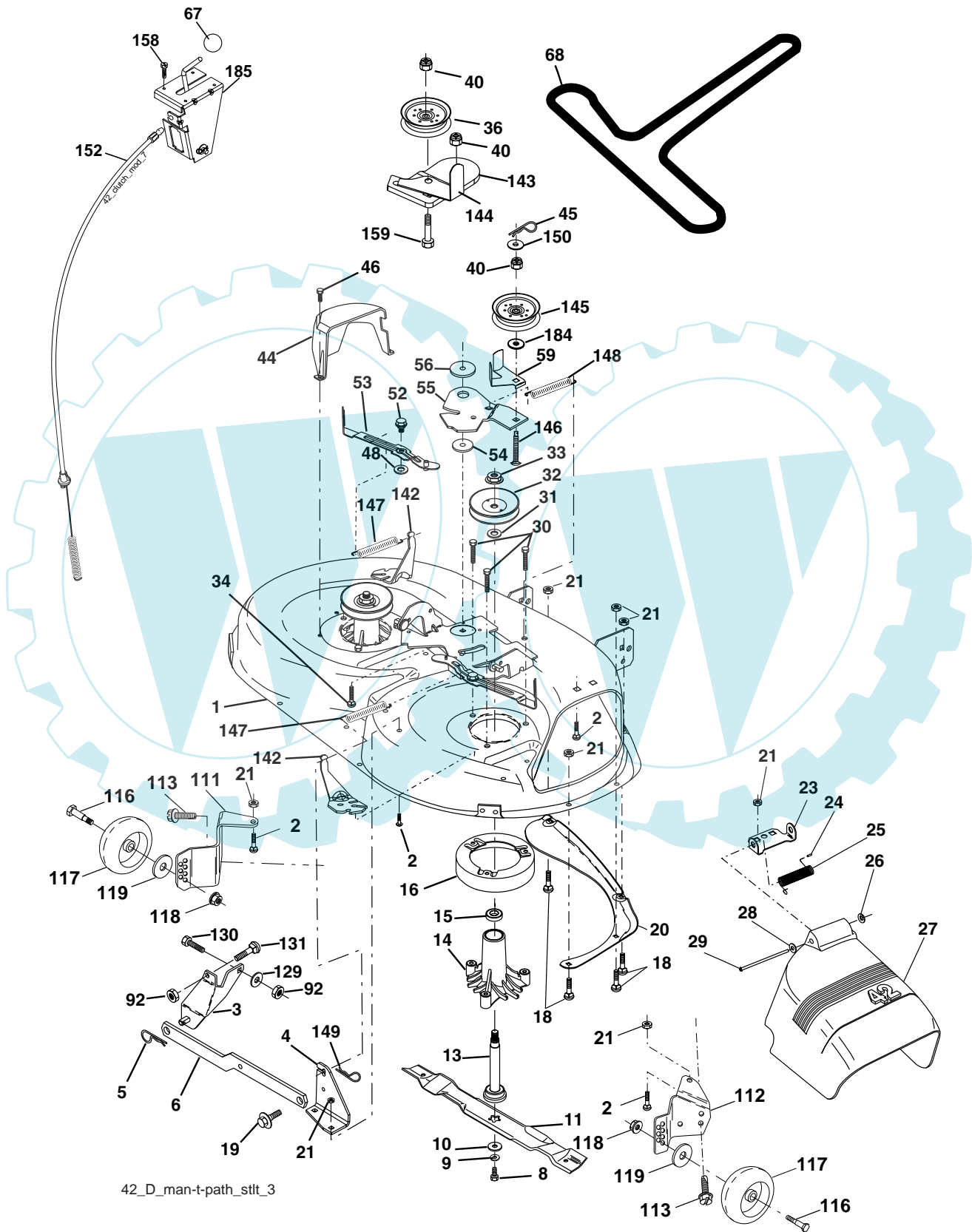

42_D_man-t-path_stlt_3

REPAIR PARTS

TRACTOR - MODEL NO. P145PH107 (P145PH107B), PRODUCT NO. 964 77 78-00
MOWER DECK

KEY NO.	PART NO.	DESCRIPTION	KEY NO.	PART NO.	DESCRIPTION
1	532 16 58-92	Housing Asm Mower 42" T-Path	56	532 16 57-23	Spacer Retainer Pm Mower
2	872 14 05-06	Bolt Rdhd Sqnk 5/16-18unc x 3/4	59	532 14 10-43	Guard TUV Idler
3	532 13 80-17	Bracket Asm Fr Sway Bar 38/42	67	532 17 15-98	Knob Rd 3/8-16 Plstc Thds Blk
4	532 16 54-60	Bracket Asm Deck 42" sway Bar	68	532 18 02-15	V-Belt Mower
5	532 12 46-70	Retainer Spring	92	873 80 06-00	Nut Lock Hex w/Ins. 3/8-16 unc
6	532 17 80-24	Bar Sway Deck	111	532 17 92-92	Bracket Wheel Gauge LH
8	532 85 08-57	Bolt 3/8 - 24 x 1.25 Gr. 8	112	532 17 92-93	Bracket Wheel Gauge RH
9	810 03 06-00	Washer Lock Hvy 3/8 Unplated	113	817 00 05-10	Bolt 5/16-18
10	532 14 02-96	Washer Hard Blade Mower	114	873 51 05-00	Nut Keps 5/16-18 Unc
11	532 13 89-71	Blade	116	532 12 48-42	Bolt Shld
13	532 13 76-45	Shaft Asm W/Lower Bearing	117	532 16 57-46	Wheel Gauge
14	532 12 87-74	Housing Mandrel Vented (Machd)	118	873 93 06-00	Nut Centerlock 3/8-16 unc
15	532 11 04-85	Bearing Ball Mandrel	119	819 12 14-14	Washer 3/8 x 7/8 x 14 Ga.
16	532 17 44-93	Stripper Round Mower	129	819 13 13-12	Washer 13/32 x 13/16 x 12 Ga.
18	872 14 05-05	Bolt Carr 5/16-18 x 5/8	130	874 78 06-16	Bolt Fin Hex 3/8-16 unc x 1 Gr. 5
19	532 13 28-27	Bolt Shoulder	131	872 14 06-08	Bolt RdHd Sqnk 3/8-16 unc x 1
20	532 15 97-70	Baffle Vortex 42"	142	532 16 58-90	Arm Spring Brake Mower
21	873 68 05-00	Nut Crown Lock 5/16-18	143	532 15 71-09	Bracket Arm Idler 42"
23	532 17 75-63	Bracket Deflector Mower 42"	144	532 15 86-34	Keeper Belt 42" Clutch Cable
24	532 10 53-04	Cap Sleeve 80 x 112 Blk Mower	145	532 16 58-88	Pulley Idler Flat
25	532 12 37-13	Spring Torsion Deflector 2 52	146	532 17 19-77	Bolt Carriage Idler
26	532 11 04-52	Nut Push Phos & Oil	147	532 17 97-48	Spring Extension
27	532 17 18-59	Shield Deflector Mower 42"	148	532 16 90-22	Spring Return Idler
28	819 11 10-16	Washer 11/32 x 5/8 x 16 Ga.	149	532 16 58-98	Retainer Spring Yellow
29	532 13 14-91	Rod Hinge 42" 6 75 Wlg	150	819 09 12-16	Washer 9/32 x 3/4 x 16 Ga.
30	532 17 39-84	Screw Thdrol	152	532 18 15-55	Clutch Cable 42"
31	532 18 76-90	Washer Spacer Mower Vented	158	817 72 04-08	Screw Hex Thd Cut 1/4-20 x 1/2
32	532 15 35-35	Pulley Mandrel 42/44/50	159	872 14 06-14	Bolt Rdhd Sqn 3/8-16 unc x 1-3/4
33	532 17 83-42	Nut Top Lock Fing	184	819 13 14-10	Washer 13/32 x 7/8 x 10 Ga.
34	872 11 06-14	Bolt Rdhd 3/8-16unc x 1-3/4 Gr. 5	185	532 18 82-34	Head Asm Cable Clutch
36	532 13 14-94	Pulley Idler Flat 3 060	--	532 13 07-94	Mandrel Asm. (Includes Housing, Shaft and Shaft Hardware Only - Pulley Not Included)
40	873 90 06-00	Nut Lock Flg. 3/8-16 unc	--	532 18 13-85	Replacement Mower, Complete (Std. Deck-Order Separately Gauge Wheel Components Key Nos. 116-119)
44	532 14 00-88	Guard Mandrel LH Black			
45	532 12 47-88	Spring Retainer 1" Zinc/cad			
46	532 13 77-29	Screw Hex Thd Cut 1/4-20 x 5/8 T			
48	532 13 39-44	Washer Hardened Smaller			
52	532 13 98-88	Bolt Shoulder 5/16-18 unc Blkz			
53	532 18 49-07	Arm Asm Pad Brake			
54	532 17 85-15	Washer Hardened			
55	532 15 50-46	Arm Idler 42" mower LT/YT			

NOTE: All component dimensions given in U.S. inches
 1 inch = 25.4 mm